

# TYPHOON INTAKE SYSTEMS®

BY 

## INSTALLATION INSTRUCTIONS

### 69-3520

### FORD

### 2003-04 THUNDERBIRD

### V8-3.9L

#### TOOLS NEEDED:

Flat blade screw driver  
Ratchet  
Extension  
8mm Socket  
10mm Socket  
11mm Socket  
4mm Allen  
10mm Wrench

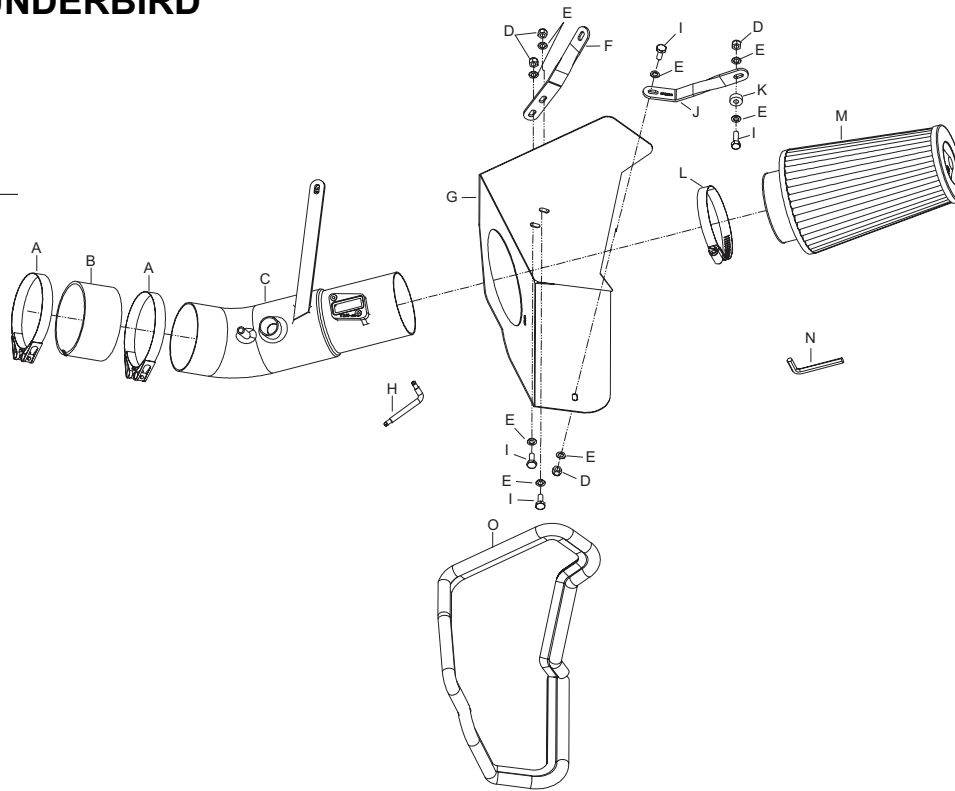

#### PARTS LIST:

Desc.	Part #	Qty.
A HOSE CLAMP #375V BARREL, SS	084065	2
B HOSE; 3-1/2"ID X 2"L, BLACK	084052	1
C INTAKE TUBE	27321	1
D NUT; 6MM NYLOCK, SS	07512	5
E WASHER; 6MM WAVE, SS	08277	9
F BRACKET; "TWISTED L" 63-1109	010084	1
G HEAT SHIELD; 63-1109	07489	1
H WRENCH; T20 TORX	69801	1
I BOLT; 6MM X 16, SS	07812	3
J BRACKET; "TWISTED C" 63-1109	010083	1
K SPACER; AL	06555	1
L HOSE CIAMP #52	08610	1
M FILTERCHARGER	RC-5122	1
N WRENCH; 9/64	69802	1
O Edge Trim 50"L	102481	1

#### TO START:

1. Turn the ignition OFF and disconnect the vehicle's negative battery cable.

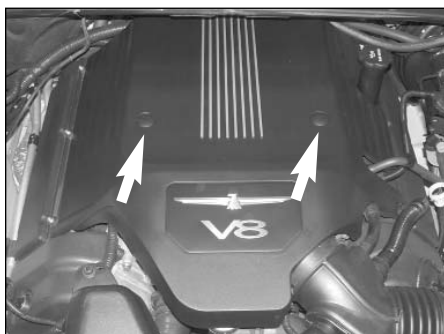

2. Remove the two plastic screws shown securing the engine cover.



3. Pull up on the rear of the engine cover to dislodge from the retaining mounts, and then remove the engine cover from the engine.



4. Pull back the red locking tab on the mass air sensor electrical connection, and then disconnect the mass air sensor electrical connection.



5. Disconnect the hoses from the stock intake tube as shown.

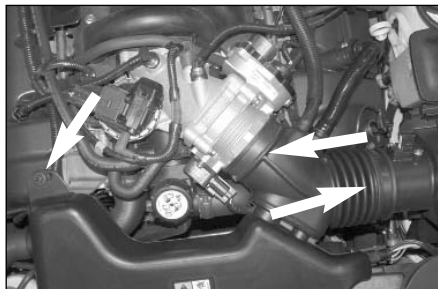

6. Loosen the hose clamps at the throttle body and the factory air box, and then remove the intake tube retaining nut shown.



7. Remove the stock intake tube assembly from the vehicle.



8. Remove the air box retaining bolt shown.



9. Pull up firmly on the air box to dislodge it from the retaining pin, and then remove the air box from the vehicle.



10. Install the provided edge trim onto the heat shield as shown.



11. Install the heat shield mounting bracket (010083) onto the heat shield as shown with the provided hardware.



12. Install the heat shield into the vehicle and secure the bracket to the factory air box mount with the factory bolt removed in step #8.



13. Install the provided 6mm bolt through the factory hole in the core support and then install the provided spacer onto the bolt as shown.

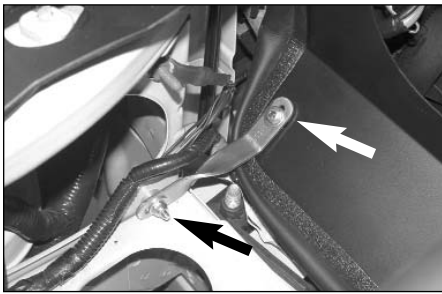

14. Install the provided heat shield bracket (010084) onto the bolt installed in step #14, and then fasten the bracket to the heat shield with the provided hardware.

**NOTE:** Use the supplied 1/4" washer as a spacer between the bracket and heat shield.



15. Install the provided silicone hose onto the throttle body and secure with the provided hose clamp.

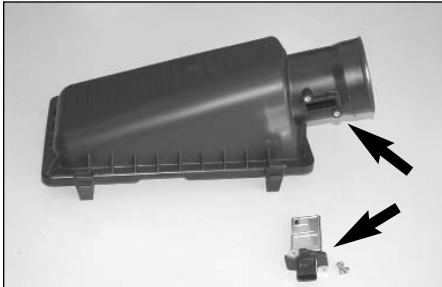

16. Using the "TORX" wrench provided, remove the mass air sensor from the air box lid as shown.

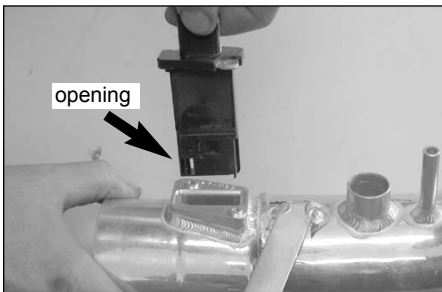

17. Install the mass air assembly into the K&N intake tube and secure with the provided hardware.

**NOTE:** Be sure to install with the opening of the mass air sensor towards the filter end of the tube as shown.

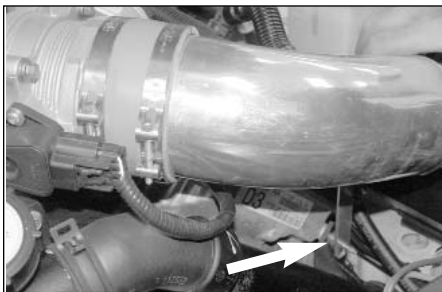

18. Install the K&N intake tube assembly into the silicone hose at the throttle body and slide the bracket onto the stock bolt as shown.



19. Secure the bracket using the provided hardware as shown.

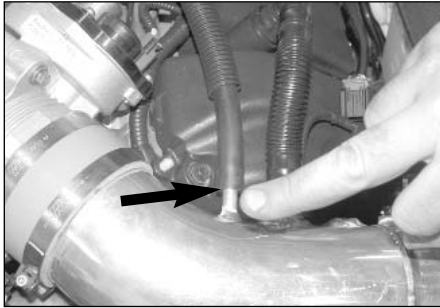

20. Install the small vent hose onto the K&N intake tube as shown.

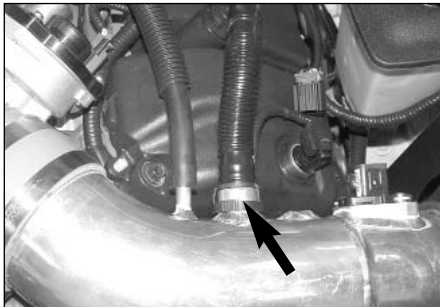

21. Install the large vent hose onto the K&N intake tube as shown.



22. Install the K&N filtercharger and secure with the provided hose clamp.

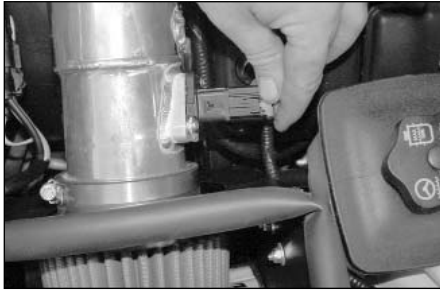

23. Reconnect the mass air sensor electrical connection.

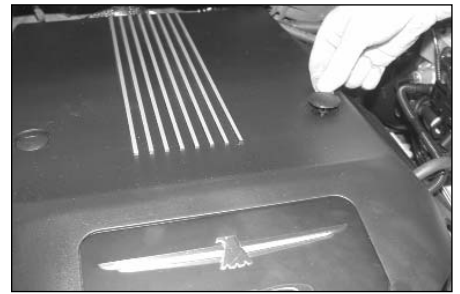

24. Reinstall the engine cover onto the rear retaining clips and then reinstall the retaining clips removed in step #2.



25. Reconnect the vehicle's negative battery cable. Double check to make sure everything is tight and properly positioned before starting the vehicle.

26. It will be necessary for all Typhoons to be checked periodically for realignment, clearance and tightening of all connections. Failure to follow the above instructions or proper maintenance may void warranty.

#### ROAD TESTING:

1. Start the engine with the transmission in neutral or park, and the parking brake engaged. Listen for air leaks or odd noises. For air leaks secure hoses and connections. For odd noises, find cause and repair before proceeding. This kit will function identically to the factory system except for being louder and much more responsive.
2. Test drive the vehicle. Listen for odd noises or rattles and fix as necessary.
3. If road test is fine, you can now enjoy the added power and performance from your kit.
4. K&N suggests checking the Filtercharger element periodically for excessive dirt build-up. When the element becomes covered in dirt (or once a year), service it according to the instructions on the Recharger service kit, part number 99-5050 or 99-5000.